

Kinetic Study of Metal Ions Adsorption by Immobilised Chitosan

Thanabalan Pitchay¹, Ali H. Jawad², Ili Syazana Johari³ and Sumiyyah Sabar^{1*}

¹*Chemical Sciences Programme, School of Distance Education (SDE), Universiti Sains Malaysia,
11800 Minden, Penang, Malaysia*

²*Faculty of Applied Sciences, Universiti Teknologi MARA (UiTM), 40450 Shah Alam, Selangor, Malaysia*

³*Department of Chemistry, Faculty of Science, Universiti Putra Malaysia,
43400 Serdang, Selangor, Malaysia*

Corresponding author: sumiyyahs@usm.my

Received: 26 October 2021; Accepted: 27 December 2021; Published: 14 January 2022

ABSTRACT

Chitosan, a biopolymer produced from crustacean shells, may be used as a sorbent for metal ions removal from industrial wastewaters. This study was carried out to evaluate the efficiency of metal ions removal from aqueous solutions using immobilised chitosan as an adsorbent in a batch adsorption system. Chitosan was immobilised on glass plates using a simple casting technique. Adsorption experiments were carried out as a function of contact time and initial metal ions concentration. The adsorption efficiency increased with increasing initial metal ions concentration (5 – 20 mg L⁻¹) and the observed trend was: Ag²⁺ > Cu²⁺ > Ni²⁺ > Fe³⁺ > Cd²⁺ > Zn²⁺. The experimental data were fitted to pseudo-first, pseudo-second-order, intra-particle, and liquid film diffusion kinetic models. The applicability of the pseudo-second-order kinetic model indicated that the adsorption behaviour was ascribed by chemisorption. Further data analysis by the diffusion kinetic models suggested that the adsorption of metal ions was controlled by more than one step: adsorption at the active sites, intra-particle, and liquid film diffusion. Overall, this work has shown the possibility of removing metal ions from water using immobilised chitosan. The use of glass plates as the solid support would facilitate the sorbent recovery during and post-adsorption process.

Keywords: *Adsorption, Chitosan, Immobilisation, Metal Ions, Kinetics*

INTRODUCTION

Metalloid contaminants have gained worldwide attention for their toxicity to humans and environments [1]. They are non-biodegradable, and the strength of metalloid toxicity relies on their redox potential and aqueous speciation in the surroundings [2]. Numerous technologies have been experimented with for treating metalloid contaminated water, such as chemical precipitation, ion exchange, membrane filtration, electrodialysis, reverse osmosis, coagulation, flocculation, and solvent extraction [3, 4]. However, some of these methods have subsequent technical complications allied with high operating costs, inefficiency in removing metal ions in trace quantities, and overabundant side production of undesirable sludge [5].

Adsorption features an impressive alternative solution in metal ions removal. Compared to other effluent treatment technology, the adsorption technology is available at a relatively low cost. The adsorbent materials are inexpensive, renewable, abundant, and potentially reusable. Chitosan has become a trustable economical adsorbent for removing metal ions from the aqueous environment [6,7]. It is formulated commercially through the deacetylation of chitin, the second abundance material after cellulose in nature. Chitosan has exceptional adsorption properties mainly due to the abundance of hydroxyl and amine groups, which operate as the coordination and reaction sites. However, chitosan beads and flakes are not reusable after some time and have limited utilisation due to their weak mechanical properties [8].

Several researchers have shown that the poor mechanical strength of chitosan could be enhanced through the immobilisation of chitosan onto solid material, such as glass beads [9], sand [10], or glass plates [11]. Glass plates have shown to be good solid support for chitosan. It can strongly adhere to the surface of the glass by coulombic attraction [8]. Adsorption studies using immobilised chitosan have been widely investigated using dyes as model pollutants. However, the adsorption of metal ions by immobilised chitosan is still very much limited. This study aims to investigate the efficiency of immobilised chitosan on glass plates for metal ions removal. Different adsorption models were adopted to describe its kinetics and rate-controlling steps. The information will be useful for further application in designing wastewater treatment systems.

EXPERIMENTAL

Materials

Chitosan flakes with an average molecular weight of 322 g mol^{-1} were obtained from Sigma-Aldrich. Cadmium chloride hydrate ($\text{CdCl}_2 \cdot x\text{H}_2\text{O}$), nickel chloride hexahydrate ($\text{NiCl}_2 \cdot 6\text{H}_2\text{O}$), copper sulphate pentahydrate ($\text{CuSO}_4 \cdot 5\text{H}_2\text{O}$), and zinc sulphate heptahydrate ($\text{ZnSO}_4 \cdot 7\text{H}_2\text{O}$) were

purchased from Ajax Chemicals. Iron (III) chloride hexahydrate ($\text{FeCl}_3 \cdot 6\text{H}_2\text{O}$) and acetic acid were from QR&C Chemicals, while silver sulphate (Ag_2SO_4) was obtained from Bendosen Laboratory Chemicals. All the other reagents used were of analytical grade and were used without further purification. Distilled water was used throughout this study.

Preparation of Immobilised Chitosan

Immobilised chitosan was prepared from the previously described method [8]. The chitosan solution was prepared by dissolving 1.50 g of chitosan flakes in 100 mL of 5 % v/v acetic acid aqueous solution in a 250 mL stopper flask. Complete dissolution was achieved by continuous agitation using a magnetic stirrer at 1000 rpm for 24 h at room temperature. The solution was cast evenly onto the surface of the glass plates (4.70 cm x 6.50 cm) at adequate wet weights to obtain a dry weight of 20 ± 2 mg adsorbent. The immobilised chitosan was left to dry completely at room temperature (27°C) for at least 48 h before use.

Batch Adsorption Experiments

The evenly cast glass plates with chitosan were immersed into a custom-made cell of dimension 5 cm x 8 cm x 1 cm that can hold up to 30 mL of solution set-up for selective contact time. An aerator made from an aquarium pump was attached to the custom-made cell via polyvinyl chloride (PVC) tubing for air supply and good agitation of the solution, as shown in Figure 1. The glass plate was placed uprightly inside the cell.

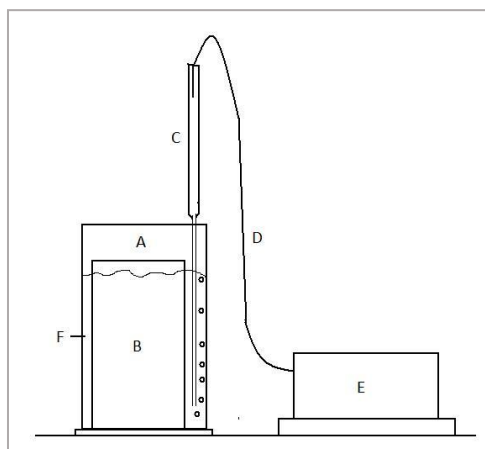

Figure 1: Experimental set-up for the adsorption of metal ions. (A) Custom-made cell, (B) Glass plate, (C) Pasteur pipette, (D) PVC tube, (E) Aquarium pump, and (F) Metal solution

A 1000 mg L⁻¹ stock solution of selected metal ions was diluted to obtain the desired concentration. A 20 mL of metal solution at a specific concentration was placed inside the custom-made cell containing the immobilised chitosan. The system was aerated at 200 mL min⁻¹ during the adsorption process. After the adsorption experiments, the concentrations of metal ions in the solutions were analysed by an atomic absorption spectrometer (AAS, PerkinElmer Analyst 400). All the experiments were replicated three times and conducted without adjusting the solution pH. The amount of metal ions adsorbed at equilibrium, q_e (mg g⁻¹), was calculated using the following equation 1:

$$q_e = \frac{(C_o - C_e)V}{m} \quad (1)$$

Where C_o is the initial metal ion concentration (mg L⁻¹); C_e is the metal ion concentration at equilibrium (mg L⁻¹); V is the volume of metal solution used (L), and m is the mass of the adsorbent used (mg).

RESULTS AND DISCUSSION

Effect of initial metal ion concentration and equilibrium time

The effect of initial metal ion concentration and the time needed for the adsorbate to achieve equilibrium are important for adsorption studies. Figure 2 shows the effects of initial metal ion concentration and contact time on the amount of (a) Ag²⁺, (b) Cu²⁺, (c) Ni²⁺, (d) Fe³⁺, (e) Cd²⁺ and (f) Zn²⁺ adsorbed by the immobilised chitosan. It can be observed that the amount of the metal ions adsorbed increased with the increase of contact time at all concentrations. The adsorption occurs most rapidly over the first 20 min. The fast adsorption occurred due to the availability of active sites at the beginning stage of adsorption [12]. The phenomenon also suggests rapid external diffusion and surface adsorption.

However, the adsorption slows down as time proceed and reaches a plateau state, indicating that equilibrium has been achieved. The equilibrium was achieved within 120 min for all the metal ions at the studied concentrations. The results signify that the binding sites on the immobilised chitosan are fully saturated after this time. Figure 2 also shows that the amount of metal ions adsorbed increased as the initial metal ions concentration increased. The trend could be explained by the higher collision rates between the metal ions and the adsorbent surface as the concentration increased. Mechanically, higher concentration gradients will lower the mass transfer resistance for metal ions to adsorb on the adsorbent [12]. The observed trend in the adsorption efficiency of the metal ions by the immobilised chitosan was: Ag²⁺ > Cu²⁺ > Ni²⁺ > Fe³⁺ > Cd²⁺ > Zn²⁺.

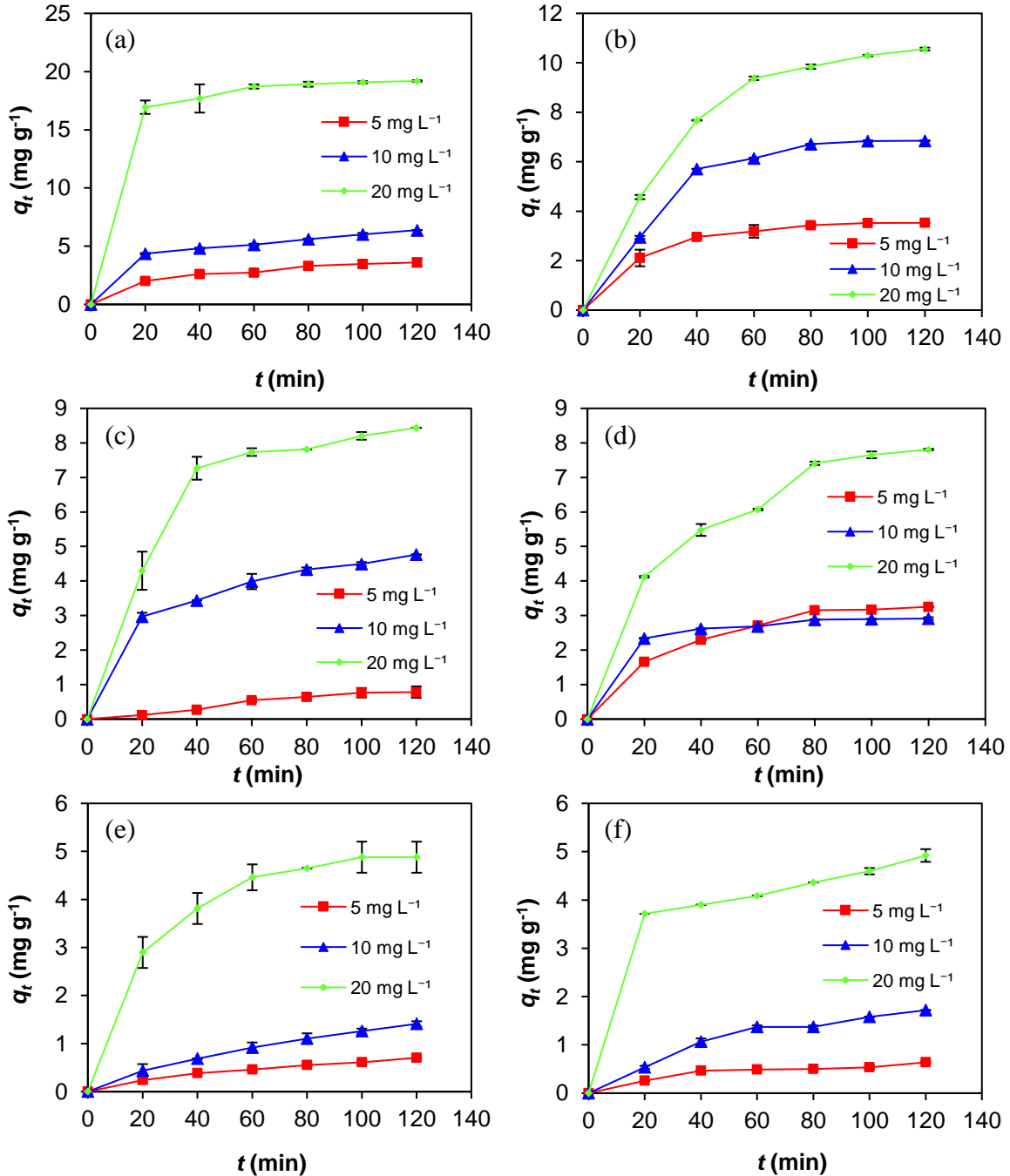

Figure 2: Effect of initial metal ions concentration and contact time on the adsorption capacities of (a) Ag²⁺, (b) Cu²⁺, (c) Ni²⁺, (d) Fe³⁺, (e) Cd²⁺ and (f) Zn²⁺ by immobilised chitosan [V: 20 mL; m: 20 mg; pH: natural pH; and T: 27 °C]

Adsorption Kinetics

Adsorption kinetics are categorised into (i) adsorption reaction models and (ii) adsorption diffusion models that provide information on the mechanism and rate-controlling steps [13]. The mechanism and rate of metal ions adsorption on the immobilised chitosan can be determined by fitting the experimental adsorption data with the pseudo-first and second-order kinetic models. Meanwhile, the adsorption diffusion was fitted by the intra-particle and liquid film diffusion models.

Pseudo-First and Pseudo-Second-Order Models

The pseudo-first-order model assumes that the rate of change of solute uptake by the adsorbent with time is directly proportional to the deviation in saturation concentration and the amount of solute uptake. The linear expression given below represents Lagergren's pseudo-first-order rate equation 2 [14]:

$$\log(q_e - q_t) = \log q_e - \frac{k_1}{2.303} t \quad (2)$$

Where q_e and q_t represent the amount of metal ions adsorbed on the immobilised chitosan (mg g^{-1}) at the equilibrium and time t , while k_1 is the rate constant (min^{-1}). The k_1 and $q_{e, cal}$ values can be calculated from the slope and intercept of the linear plot of $\log(q_e - q_t)$ versus t .

The pseudo-second-order model is based on the adsorption capacity of the solid phase, and it visualises chemisorption as the rate-controlling step. The pseudo-second-order kinetic is expressed in linear form in the following equation 3 [15]:

$$\frac{t}{q_t} = \frac{1}{k_2 q_e^2} + \frac{t}{q_e} \quad (3)$$

The slope and intercept of the linear plot of t/q_t versus t give the values of $q_{e, cal}$, and k_2 , respectively. The pseudo-first and second-order kinetic constants with their correlation coefficients are presented in Table 1. The correlation coefficients for the pseudo-second-order model were greater than the pseudo-first-order kinetic model. In addition, the theoretical equilibrium adsorption capacity values and experimental adsorption capacities were in excellent agreement. The findings imply that chemisorption is the main adsorption mechanism for the investigated metal ions adsorption on the immobilised chitosan. In this case, surface complexation is the rate-limiting

step involving valence forces by sharing or exchanging electrons between adsorbent and adsorbate [11].

Although the adsorption capacities increase as the metal ions concentration increases, the removal rate may decrease due to inadequacies of mass transfer in retrieving the active sites of the adsorbent. The competition for active sites on chitosan is high when more metal ions are present in the solution, and consequently, the chances of the metal ions binding to active sites are high. However, there are some possibilities that a layer of saturated metal ions blocks the active surface sites. As a result, the metal ions have to work harder to interact with the active sites on the adsorbent by diffusing through pores to the inner layer of the chitosan [16].

Table 1: The pseudo-first- and second-order kinetic models for the adsorption of metal ions by immobilised chitosan

Initial metal ions concentration (mg L ⁻¹)	$q_{e,exp}$ (mg L ⁻¹)	Pseudo-first-order model			Pseudo-second-order model		
		$q_{e,cal}$ (mg g ⁻¹)	$k_1 \times 10^{-2}$ (min ⁻¹)	R^2	$q_{e,cal}$ (mg g ⁻¹)	$k_2 \times 10^{-3}$ (g mg ⁻¹ min ⁻¹)	R^2
Ag²⁺							
5	3.60	3.49	3.04	0.934	4.38	8.26	0.986
10	6.38	3.48	2.03	0.938	7.09	7.86	0.988
20	19.2	5.60	3.89	0.982	19.8	13.0	1.00
Cu²⁺							
5	3.53	6.39	5.80	0.925	4.07	14.7	0.998
10	6.85	19.4	6.61	0.948	8.90	3.69	0.969
20	10.6	13.0	3.82	0.993	13.9	2.05	0.987
Ni²⁺							
5	0.781	2.26	4.19	0.891	1.44	7.17	0.959
10	4.77	3.20	2.44	0.990	5.49	8.71	0.995
20	8.44	5.89	3.18	0.923	10.0	4.91	0.989
Fe³⁺							
5	3.25	4.39	4.17	0.936	4.12	8.12	0.994
10	2.91	1.83	4.56	0.934	3.09	45.4	0.999
20	7.81	11.2	4.03	0.933	9.89	3.26	0.989
Cd²⁺							
5	0.705	4.39	4.17	0.936	1.13	11.1	0.973
10	1.41	1.73	2.28	0.972	2.62	3.57	0.981
20	4.88	4.28	3.71	0.993	5.73	9.23	0.998
Zn²⁺							
5	0.638	0.399	1.40	0.837	0.787	33.4	0.949
10	1.72	1.83	2.44	0.942	2.75	5.02	0.944
20	4.92	1.88	1.61	0.940	5.26	14.6	0.989

Intra-Particle Diffusion Model

The intra-particle diffusion model was used to verify whether the adsorption rate was dominated by the internal transport of the metal ions into the chitosan pores. The intra-particle diffusion model is expressed in equation 4 [17]:

$$q_t = k_i t^{1/2} + C \quad (4)$$

Where k_i is the intra-particle diffusion rate constant ($\text{mg g}^{-1} \text{min}^{-1}$), C reflects the boundary layer thickness (mg g^{-1}). The k_i and C values can be obtained from the slope and intercept of the linear plot of q_t versus $t^{1/2}$. As summarised in Table 2, the rate parameter k_i and the intercept C_2 values related to the intra-particle diffusion increase with the increased concentration of metal ions. The findings suggest greater boundary layer effects and higher driving force with increasing metal ions concentration [18]. Besides, the linear plot of q_t against $t^{1/2}$ does not pass through the origin for all the studied metal ions. The findings revealed that intra-particle diffusion was not the only rate-controlling step. However, some degrees of the boundary layer diffusion also control the adsorption of metal ions onto the immobilised chitosan.

Table 2: Parameters of the intra-particle and film diffusion models for metal ions adsorption by immobilised chitosan

Initial metal ions concentration (mg L^{-1})	$q_{e,exp}$ (mg L^{-1})	Intra-particle diffusion			Film diffusion	
		k_i ($\text{mg g}^{-1} \text{min}^{-1}$)	C (mg g^{-1})	R^2	$K_{fd} \times 10^{-2}$ (min^{-1})	R^2
Ag²⁺						
5	3.60	0.267	0.829	0.948	3.06	0.962
10	6.38	0.270	3.12	0.987	2.45	0.937
20	19.2	0.471	14.8	0.965	4.77	0.950
Cu²⁺						
5	3.53	0.289	0.935	0.939	5.39	0.941
10	6.85	0.818	-0.248	0.886	5.87	0.943
20	10.6	1.21	-0.441	0.950	3.69	0.994
Ni²⁺						
5	0.781	0.124	-0.459	0.971	3.42	0.855
10	4.77	0.312	1.54	0.993	2.73	0.981
20	8.44	0.780	1.42	0.806	3.44	0.954
Fe³⁺						
5	3.25	0.330	0.187	0.999	3.95	0.954
10	2.91	0.114	1.85	0.968	4.90	0.961
20	7.81	0.699	0.965	0.975	3.79	0.950

Cd²⁺						
5	0.705	0.0688	-0.0656	0.995	1.95	0.993
10	1.41	0.150	-0.242	0.998	2.14	0.976
20	4.88	0.405	1.17	0.970	3.84	0.995
Zn²⁺						
5	0.638	0.0534	0.0595	0.799	1.75	0.891
10	1.72	0.195	-0.256	0.909	2.41	0.964
20	4.92	0.141	3.05	0.962	2.36	0.817

Liquid Film Diffusion Model

The Boyd model was applied to differentiate between the film and intra-particle diffusion. The model is generally given in its linearised form by equation (5) [19]:

$$\ln\left(1 - \frac{q_t}{q_e}\right) = -k_{fd}t \quad (5)$$

Where k_{fd} is the liquid film diffusion constant (min^{-1}). The value is obtained from the gradient of the linear plots of $\ln(1 - q_t/q_e)$ versus t . Based on the calculated values listed in Table 2, the R^2 values obtained from the linearised Boyd model were relatively comparable to the intra-particle diffusion model. The finding signified that the rate-limiting step for the adsorption of metal ions by the immobilised chitosan was controlled by both intra-particle and liquid film diffusion.

CONCLUSION

In this study, immobilised chitosan on glass plates was used as an adsorbent to remove metal ions from the aqueous solution. The adsorption capacities of Ag^{2+} , Cu^{2+} , Ni^{2+} , Fe^{3+} , Cd^{2+} , and Zn^{2+} were 19.2, 10.6, 8.44, 7.81, 4.88, and 4.92 at an initial concentration of 20 mg L^{-1} and adsorbent dosage of 20 mg. Kinetic studies showed that the adsorption agreed to the pseudo-second-order model, confirming that the primary adsorption mechanism is chemisorption. Besides, the intra-particle and liquid film diffusion may also be controlling the adsorption of metal ions by the immobilised chitosan.

ACKNOWLEDGMENTS

The authors would like to acknowledge Universiti Sains Malaysia (USM) for the financial support through Short Term Research Grant (304/PJJAUH/6313104). The authors also would like to thank



the School of Distance Education and School of Chemical Sciences, USM, for their research facilities.

AUTHOR'S CONTRIBUTION

Thanabalan Pitchay carried out the research and wrote the article. Sumiyyah Sabar designed the study, supervised research progress. Ali H. Jawad, Ili Syazana Johari, and Sumiyyah Sabar conceptualised the central research idea and theoretical framework. They also anchored the review, revisions and approved the article submission.

CONFLICT OF INTEREST STATEMENT

The authors agree that this research was conducted without any self-benefits, commercial or financial conflicts and declare the absence of conflicting interests with the funders.

REFERENCES

- [1] Monier, M. (2012). Adsorption of Hg²⁺, Cu²⁺ and Zn²⁺ ions from aqueous solution using formaldehyde cross-linked modified chitosan–thioglyceraldehyde Schiff's base. *International Journal of Biological Macromolecules*, 50(3), 773-781. <https://doi.org/10.1016/j.ijbiomac.2011.11.026>
- [2] Bailey, S. E., Olin, T. J., Bricka, R. M., & Adrian, D. D. (1999). A review of potentially low-cost sorbents for heavy metals. *Water Research*, 33(11), 2469-2479. [https://doi.org/10.1016/S0043-1354\(98\)00475-8](https://doi.org/10.1016/S0043-1354(98)00475-8)
- [3] Kamari, A., & Ngah, W. W. (2009). Isotherm, kinetic and thermodynamic studies of lead and copper uptake by H₂SO₄ modified chitosan. *Colloids and Surfaces B: Biointerfaces*, 73(2), 257-266. <https://doi.org/10.1016/j.colsurfb.2009.05.024>
- [4] Rangel-Mendez, J. R., Monroy-Zepeda, R., Leyva-Ramos, E., Diaz-Flores, P. E., & Shirai, K. (2009). Chitosan selectivity for removing cadmium (II), copper (II), and lead (II) from aqueous phase: pH and organic matter effect. *Journal of Hazardous Materials*, 162(1), 503-511. <https://doi.org/10.1016/j.jhazmat.2008.05.073>
- [5] Nair, V., Panigrahy, A., & Vinu, R. (2014). Development of novel chitosan–lignin composites for adsorption of dyes and metal ions from wastewater. *Chemical Engineering Journal*, 254, 491-502. <https://doi.org/10.1016/j.cej.2014.05.045>

- [6] Kuczajowska-Zadrożna, M., Filipkowska, U., & Józwiak, T. (2020). Adsorption of Cu (II) and Cd (II) from aqueous solutions by chitosan immobilised in alginate beads. *Journal of Environmental Chemical Engineering*, 8(4), 103878. <https://doi.org/10.1016/j.jece.2020.103878>
- [7] Alam, O., Qiao, X., & Nath, T. K. (2020). The effect of Ca-bearing contents in chitosan on Pb 2+, Cd 2+ and Cu 2+ adsorption and its adsorption mechanism. *Journal of Environmental Health Science and Engineering*, 18(2), 1401-1414. <https://doi.org/10.1007/s40201-020-00556-y>
- [8] Nawi, M. A., Sabar, S., Jawad, A. H., & Ngah, W. W. (2010). Adsorption of Reactive Red 4 by immobilised chitosan on glass plates: towards the design of immobilised TiO₂-chitosan synergistic photocatalyst-adsorption bilayer system. *Biochemical Engineering Journal*, 49(3), 317-325. <https://doi.org/10.1016/j.bej.2010.01.006>
- [9] Shen, C., Wang, Y., Xu, J., & Luo, G. (2013). Chitosan supported on porous glass beads as a new green adsorbent for heavy metal recovery. *Chemical Engineering Journal*, 229, 217-224. <https://doi.org/10.1016/j.cej.2013.06.003>
- [10] Hsien, K. J., Futralan, C. M., Tsai, W. C., Kan, C. C., Kung, C. S., Shen, Y. H., & Wan, M. W. (2013). Adsorption characteristics of copper (II) onto non-crosslinked and cross-linked chitosan immobilised on sand. *Desalination and Water Treatment*, 51(28-30), 5574-5582. <https://doi.org/10.1080/19443994.2013.770191>
- [11] Mubarak, N. S. A., Chuan, T. W., Khor, H. P., Jawad, A. H., Wilson, L. D., & Sabar, S. (2021). Immobilised Fe-loaded chitosan film for methyl orange dye removal: competitive ions, reusability, and mechanism. *Journal of Polymers and the Environment*, 29(4), 1050-1062. <https://doi.org/10.1007/s10924-020-01949-8>
- [12] Shankar, P., Gomathi, T., Vijayalakshmi, K., & Sudha, P. N. (2014). Comparative studies on the removal of heavy metals ions onto cross linked chitosan-g-acrylonitrile copolymer. *International Journal of Biological Macromolecules*, 67, 180-188. <https://doi.org/10.1016/j.ijbiomac.2014.03.010>
- [13] Oladipo, A. A., Gazi, M., & Saber-Samandari, S. (2014). Adsorption of anthraquinone dye onto eco-friendly semi-IPN biocomposite hydrogel: equilibrium isotherms, kinetic studies and optimisation. *Journal of the Taiwan Institute of Chemical Engineers*, 45(2), 653-664. <https://doi.org/10.1016/j.jtice.2013.07.013>
- [14] Lagergren, S. (1898). Zur theorie der sogenannten adsorption gelöster stoffe. *Kungliga Svenska Vetenskapsakademiens Handlingar*, 24 (1898) 1-39.
- [15] Ho, Y. S., & McKay, G. (1998). Kinetic models for the sorption of dye from aqueous solution by wood. *Process Safety and Environmental Protection*, 76(2), 183-191. <https://doi.org/10.1205/095758298529326>
- [16] Adamczuk, A., & Kołodyńska, D. (2015). Equilibrium, thermodynamic and kinetic studies on removal of chromium, copper, zinc and arsenic from aqueous solutions onto fly ash coated by chitosan. *Chemical Engineering Journal*, 274, 200-212. <https://doi.org/10.1016/j.cej.2015.03.088>



- [17] Weber Jr, W. J., & Morris, J. C. (1963). Kinetics of adsorption on carbon from solution. *Journal of The Sanitary Engineering Division*, 89(2), 31-59. <https://doi.org/10.1061/JSEDAI.0000430>
- [18] Tanhaei, B., Ayati, A., Lahtinen, M., & Sillanpää, M. (2015). Preparation and characterisation of a novel chitosan/Al₂O₃/magnetite nanoparticles composite adsorbent for kinetic, thermodynamic and isotherm studies of Methyl Orange adsorption. *Chemical Engineering Journal*, 259, 1-10. <https://doi.org/10.1016/j.cej.2014.07.109>
- [19] Boyd, G. E., Adamson, A. W., & Myers Jr, L. S. (1947). The exchange adsorption of ions from aqueous solutions by organic zeolites. II. Kinetics1. *Journal of the American Chemical Society*, 69(11), 2836-2848. <https://doi.org/10.1021/ja01203a066>